



R E P U B L I C

Blower Systems®

Republic Regenerative Blower **HRB 100**

Republic offers a complete line of regenerative blowers for high vacuum or compressed air applications in both horizontal and vertical mounted positions. TEFC motors are UL, cUL and CE certified. The impeller is directly connected to the motor shaft, providing powerful air force without undue friction. The bearings are outside the compression chamber, ensuring maximum operational reliability under high differential pressure. This low-maintenance, oil-free design provides continuous, dependable service to our customers.

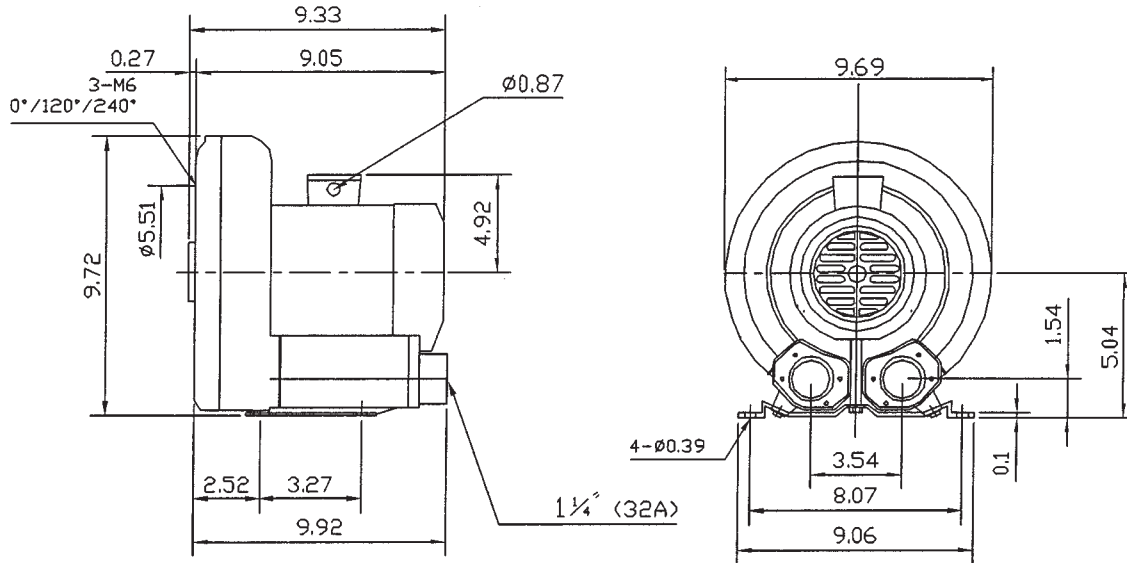
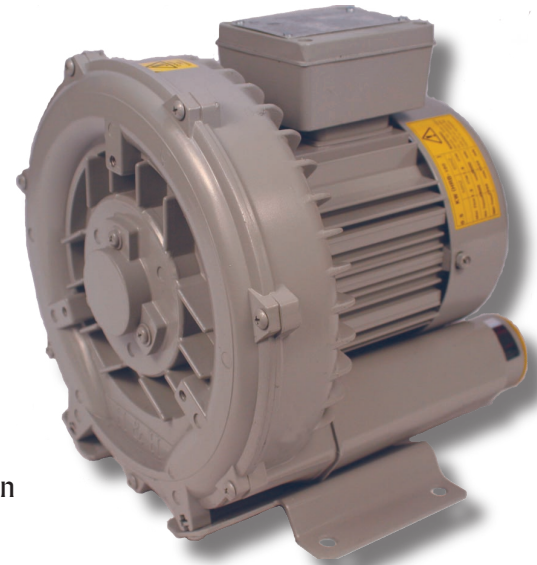

Advantages

- ▲ Low noise 64dB
- ▲ Continuous, low-maintenance operation
- ▲ Saves space and electricity
- ▲ Trouble-free installation
- ▲ Easy replacement of parts
- ▲ Outboard bearings yielding longer life

Product Options

- ▲ 1-1/4" Relief Valve (recommended)
- ▲ Inlet Filter (recommended)
- ▲ Liquid filled gauge
- ▲ Check Valve
- ▲ Belt-driven bare shaft blowers are available
- ▲ Explosion proof motors available
(Class 2/GroupB/Division 1 Certified)

Model	Phase	Motor (HP)	Current @230 V	Sound Level (dB)	Rated Pressure (in. H ₂ O)	Rated Vacuum (in. H ₂ O)	Air flow (cfm)	Weight (lbs)
HRB100	3	.67	2.4	64	51	40	50	26



Republic Regenerative Blower **HRB 100**

REPUBLIC
Blower Systems®

Pressure vs. CFM

Vacuum vs. CFM

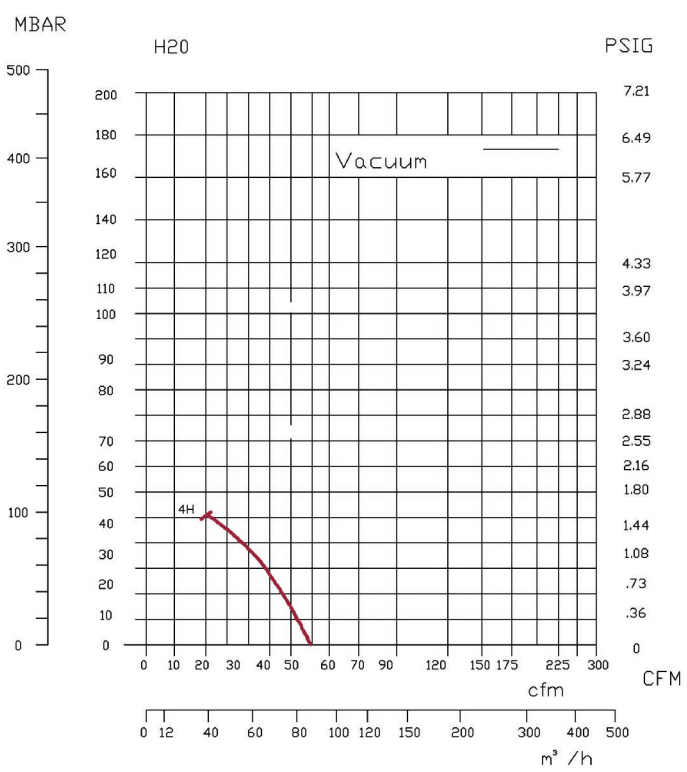
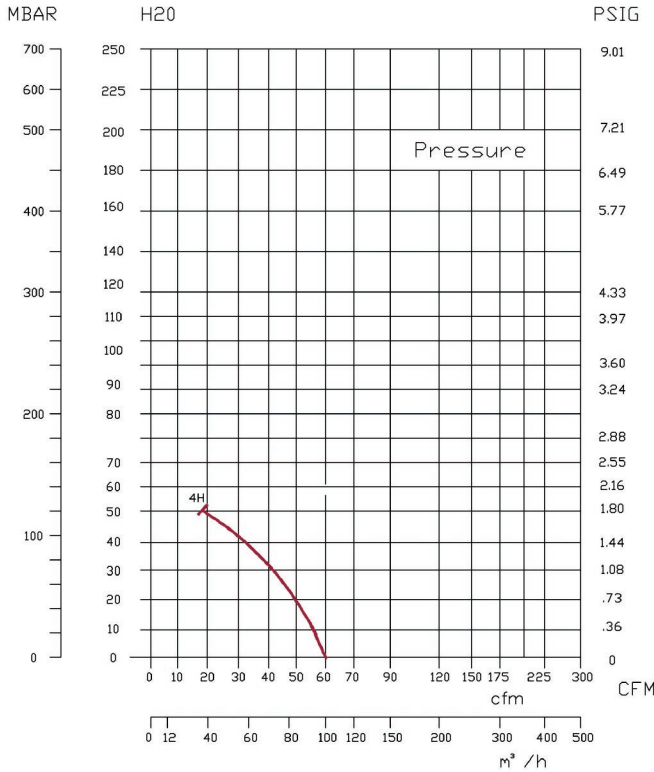

Performance for all blowers is 60 Hz. Ask for information on 50 Hz.

All Republic Regenerative Blowers are available in preassembled kits for either pressure or vacuum applications. These kits include an inlet filter and relief valve, and have been tested prior to shipment. Optional items for these kits include check valve and gauge.

KPHRB100 - Pressure Kit Drawing

KVHRB100 - Vacuum Kit Drawing

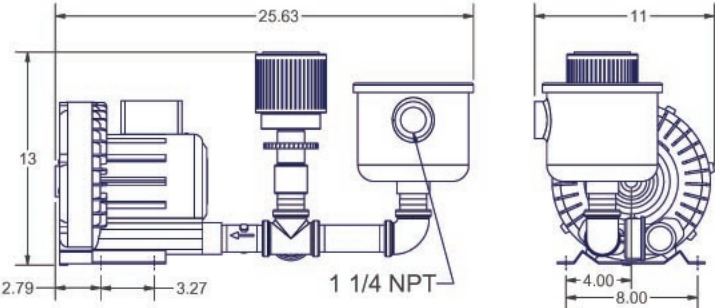
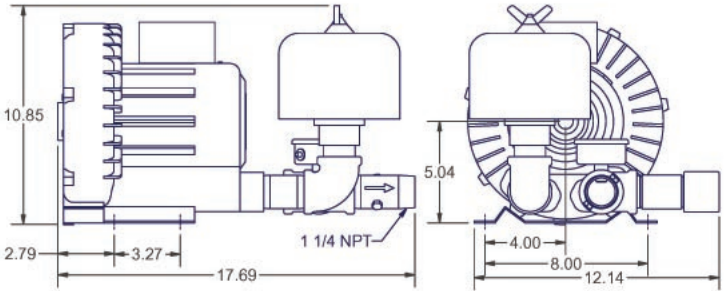

Kit Pressure Pump 1 1/4" NPT KPHRB100

Kit Vacuum Pump 1 1/4" Kit KVHRB100

5131 Cash Road ▲ Dallas, TX 75247 ▲ P 214.631.8070 ▲ F 214.631.3673 ▲ 800.847.0380

www.republicsales.com

©Republic Blower Systems®
Created 03.06